

Exploiting Error-Control Coding in Blind Channel Estimation

Renato R. Lopes and John R. Barry

School of Electrical and Computer Engineering
Georgia Institute of Technology, Atlanta, Georgia 30332-0250

Abstract — Despite the widespread use of forward-error control (FEC) coding, most channel estimation techniques ignore its presence, and instead make the simplifying assumption that the transmitted symbols are uncoded. However, FEC induces structure in the transmitted sequence that can be exploited to improve channel estimates. Furthermore, soft-output decoding can improve decision-driven techniques. In this work we propose a technique for exploiting FEC in channel estimation that combines iterative channel estimation with turbo equalization. We present one example showing that an estimator that exploits FEC can attain the same accuracy as one that ignores FEC, but with an SNR that is 6 dB lower.

I. INTRODUCTION

Practical communications systems use forward-error control (FEC) coding, which restricts the possible transmitted sequences so as to increase their minimum distance, thus reducing the signal-to-noise ratio (SNR) required to attain a given bit-error rate. Nevertheless, the presence of FEC codes is seldom exploited in decision-directed and blind estimation techniques. Rather, most estimators assume the channel inputs are independent, identically distributed (i.i.d.) over a finite alphabet. In fact, at sufficiently high SNR, even decision-directed blind iterative estimation techniques that ignore FEC can perform well [1,2]. There is then little incentive to incur the extra complexity required to exploit FEC. However, the last decade has seen the discovery of powerful FEC techniques that, with reasonable complexity, allow reliable transmission at an SNR only fractions of a dB from channel capacity [3-5]. When powerful codes are used at low SNR, estimation techniques that ignore FEC are doomed to fail.

There is little prior work that relates FEC to channel estimation. In [6] it was shown that FEC, though violating the i.i.d. assumption, does not hurt the performance of some blind equalizers that rely on this assumption. Yet, practical blind estimators that benefit from FEC were unknown until the estimators of [7-9] were proposed. These techniques combine the good performance of blind iterative channel estimation [1,2], shown in Fig. 1(a), and turbo equalization [10-12], shown in Fig. 1(b). As illustrated in Fig. 1(a) and (b), both are based on an iterative exchange of information between blocks.

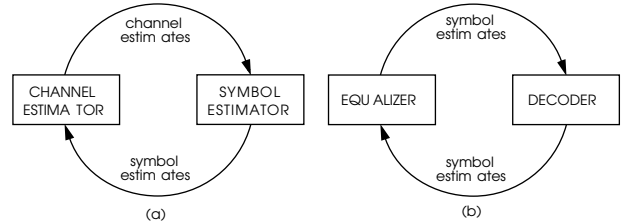

Fig. 1. A blind iterative channel estimator (a) iterates between channel estimation and equalization; a turbo equalizer (b) iterates between equalization and decoding.

In Fig. 1(a), the symbol estimator uses the channel estimates to compute soft estimates of the transmitted sequence. The channel estimator then uses these soft symbol estimates to improve the channel estimates, which in turn produce better symbol estimates, and so on. However, FEC is ignored. Likewise, in the turbo equalizer of Fig. 1(b), soft symbol information from the FEC decoder is used as *a priori* information to improve the soft symbol estimates produced by the equalizer. These estimates are then passed back to the decoder, and so on. Here, channel knowledge is assumed. In this work, the two techniques of Fig. 1(a) and (b) will be combined into a single, practical method for exploiting FEC in blind channel estimation.

The FEC-aware schemes of [7-9] are based on the channel estimator of [1]. In contrast, we propose a blind iterative FEC-aware channel estimator based on the channel estimator of [2], which has lower complexity and improved convergence, being less likely to become trapped in a undesirable stationary point of the iterative scheme. Furthermore, the soft-output equalizer in [7-9] is based on the BCJR algorithm [13], which has complexity exponential in the channel memory. In contrast, we propose a soft-output equalizer based on a modified decision-feedback equalizer (DFE) [14] which has complexity linear in the number of equalizer coefficients, making it feasible to apply the proposed techniques to long channels with severe ISI.

II. CHANNEL MODEL AND PROBLEM STATEMENT

Consider the system model shown in Fig. 2, where a binary message $\mathbf{m} = [m_0, \dots, m_{K-1}]$ of length K is encoded by a rate K/N encoder, producing a codeword $\mathbf{c} = [c_0, \dots, c_{N-1}]$ of

This research was supported in part by NSF grant number ITR-0082329 and by CAPES-Brazil grant number BEX 1376/96-9.

length N , with each symbol drawn from the binary alphabet $\{\pm 1\}$. The codeword is then permuted according to an interleaver π , resulting in the transmitted sequence $\mathbf{a} = [a_0, \dots, a_{N-1}]$, with $a_k = c_{\pi(k)}$. Let $\mathbf{r} = [r_0, \dots, r_{L-1}]$ denote the received sequence, where $L = N + \mu$, and where:

$$r_k = \mathbf{h}^T \mathbf{a}_k + n_k, \quad (1)$$

where the channel impulse response is $\mathbf{h} = [h_0, \dots, h_{\mu}]^T$, $\mathbf{a}_k = [a_k, \dots, a_{k-\mu}]^T$ is a vector of channel inputs, and $n_k \sim \mathcal{N}(0, \sigma^2)$ represents the white Gaussian noise.

The *blind estimation problem* is to estimate \mathbf{h} and σ^2 from \mathbf{r} , without the assistance of training (i.e., without knowledge of \mathbf{m}). Instead, the estimator must rely solely on its knowledge of the probability distribution function (pdf) of \mathbf{m} , assumed here to be uniform, knowledge of the encoder and interleaver, and knowledge of the channel model (1). The *joint maximum-likelihood estimator* [15] would choose \mathbf{h} , σ^2 , and \mathbf{m} so as to jointly maximize $p(\mathbf{r} | \mathbf{m}; \mathbf{h}, \sigma^2)$, the conditional pdf of \mathbf{r} given \mathbf{h} , σ^2 , and \mathbf{m} . Its complexity is prohibitive, however, and thus we seek lower complexity approximations.

III. BACKGROUND

Unlike the joint ML estimator, a conventional receiver deals with the tasks of channel estimation, equalization and FEC decoding separately. This approach is suboptimal, and performance can be improved with iterative techniques such as turbo equalizers and iterative channel estimators.

A key ingredient of iterative algorithms is the use of soft symbol estimates, which, for a BPSK system, takes the form of the log-likelihood ratio (LLR):

$$\lambda_k = \log \frac{\Pr(a_k = 1 | \mathbf{r})}{\Pr(a_k = -1 | \mathbf{r})}. \quad (2)$$

The BCJR algorithm [13] computes λ_k exactly, while the decision-aided equalizer [16] and the soft-output DFE [2] provide reduced-complexity approximations. The LLR can be used to compute two important quantities:

- Maximum *a posteriori* (MAP) decision: $\hat{a}_k = \text{sign}(\lambda_k)$,
- *A posteriori* expectation: $\tilde{a}_k = \mathbb{E}[a_k | \mathbf{r}] = \tanh(\lambda_k / 2)$.

The iterative channel estimators of [1,2] deal with a simplified blind channel estimation problem in which FEC is ignored, and instead the transmitted symbols are assumed to

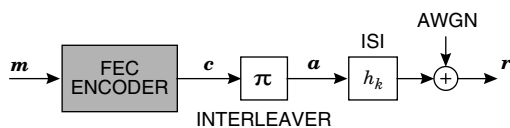

Fig. 2. Transmitter and channel model.

be i.i.d. uniform. The problem is then to choose \mathbf{h} , σ^2 , and \mathbf{a} so as to jointly maximize the likelihood $p(\mathbf{r} | \mathbf{a}; \mathbf{h}, \sigma^2)$. Even this simplified ML estimator is generally infeasible, since it would require that all 2^N possible sequences \mathbf{a} be tested. An alternative of reasonable complexity is the EM algorithm [1], which generates a sequence of estimates with non-decreasing likelihood and with proper initialization may converge to the ML solution. The extended-window EM algorithm [2] is a related lower complexity algorithm that is less prone to being caught in a local maximum of the likelihood function.

Turbo equalizers [10-12] also deals with a simplified problem by assuming channel knowledge. In this case, an ideal receiver that jointly equalizes and decodes would find the information sequence \mathbf{m} that maximizes $p(\mathbf{r} | \mathbf{m})$. Solving this problem exactly is computationally hard, since the presence of the interleaver implies that the number of states in the joint encoder/channel super-trellis can be large. Turbo equalization provides a low-complexity iterative approximate solution. Key to its success is the fact that only extrinsic information is exchanged between the equalizer and the decoder. The extrinsic information provided by the equalizer can be seen as the information on the transmitted bits gained at the equalizing stage by exploiting only the structure of the channel. Similarly, the extrinsic information provided by the decoder contains the information about the transmitted bits that was not apparent to the FEC-ignorant equalizer. The equalizer and decoder use this extrinsic information as *a priori* information to compute new values for λ_k . The extrinsic information, denoted by λ'_k , is computed as the difference between this new value of λ_k and the extrinsic information used in its computation.

IV. FEC-AWARE BLIND CHANNEL ESTIMATION

One important aspect of turbo equalizers is that they provide soft estimates of the transmitted sequence that benefit from the FEC code structure, and are much more reliable than the estimates provided by an equalizer alone. It seems natural that using this information for channel estimation should provide better results than using FEC-ignorant symbol estimates, as is done in Fig. 1(a). Thus, we propose the channel estimator of Fig. 3, in which the symbol estimator in Fig. 1(a) is replaced by the turbo equalizer of Fig. 1(b).

The proposed estimator of Fig. 3 iterates between three blocks: a channel estimator, a soft-output equalizer, and a soft-output FEC decoder. A receiver would have to perform these functions anyway, so their presence alone does not imply any added complexity; the only added complexity is due to fact that these functions are performed multiple times as the algorithm iterates.

It is instructive to compare the proposed estimator with a conventional receiver that performs channel estimation just once, then uses these estimates in a turbo equalizer. The proposed estimator can be derived from this receiver by making just one modification: Rather than using the initial channel estimates for every turbo iteration, the proposed receiver occasionally improves the channel estimates based on tentative soft decisions. Specifically, every J -th iteration of the turbo equalizer, the soft-symbol estimates produced by the FEC decoder are used by the extended window algorithm to produce better channel estimates, which are then used for the next J iterations. Key to the good performance is the fact that the a priori information for the soft-output equalizer is not initialized to zero after J iterations of the turbo equalizer, but instead, extrinsic information from the last instance is used as the initial *a priori* information in the next one. The choice of J is a design parameter that can affect convergence speed, steady-state behavior, and overall complexity. Because of the low complexity of the channel estimator relative to the complexity of the equalizer and FEC decoder, we have found empirically that $J = 1$ is a reasonable choice. With this choice, each time the FEC decoder passes extrinsic information to the equalizer, the channel estimates are simultaneously improved. This is only marginally more complex than a conventional receiver that uses turbo equalization, but the performance improvement that results can be significant.

V. SOFT DFE WITH A PRIORI INFORMATION

In [2] we showed how a DFE can be used to approximate a soft-output BCJR equalizer, but with significantly lower complexity. We now expand that idea to incorporate *a priori* information, making it useful as an inner equalizer in a turbo equalization system.

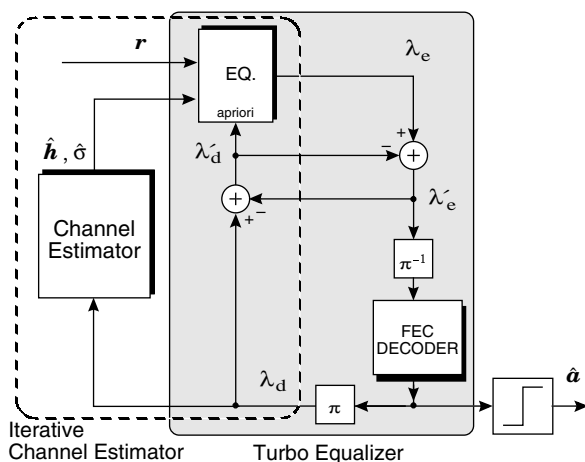

Fig. 3. Integrating channel estimation with turbo equalization.

Let z_k be the output of an MMSE-DFE with r_k as its input, N_f forward taps and N_b backward taps. This relationship is illustrated in Fig. 4. Roughly speaking, the equalizer eliminates ISI from its output, so that we may write $z_k \approx Aa_k + v_k$, where A is the amplitude of the equivalent memoryless channel between a_k and z_k , and v_k is the equivalent noise with variance σ_v^2 . This noise includes residual ISI, but we may approximate it as AWGN. We may thus approximate the extrinsic LLR by $\lambda_k' \approx 2Az_k/\sigma_v^2$. This information is extrinsic because it depends only on the structure of the channel. Any a priori information from the FEC decoder should be added to λ_k' to produce the full LLR λ_k . Since the full LLR will provide more reliable decisions than the extrinsic information alone, λ_k should be used to compute symbol estimates in the feedback loop of the DFE, as illustrated in Fig. 4.

Computation of the coefficient vectors \mathbf{f} and \mathbf{b} is easy if the channel is known [14, p. 542]. Obviously, the channel information is not available, but in keeping with the iterative paradigm of Fig. 3 we may compute \mathbf{f} and \mathbf{b} using the current estimates $\hat{\mathbf{h}}$ and $\hat{\sigma}$. We also propose to use the soft information $\tilde{a}_k = \tanh(\lambda_k/2)$, as opposed to the traditional hard information coming from a slicer, in the feedback loop. As in [2], we estimate A and σ_v^2 using a scalar channel version of EM.

VI. SIMULATION RESULTS

In this section we present simulation results that illustrate the performance of the proposed estimation algorithm. For all the experiments, the channel estimates were initialized by measuring the energy of the received signal, and assigning half to signal and half to noise, yielding $\hat{\sigma}_{(0)}^2 = \sum_{k=0}^{L-1} r_k^2 / (2L)$ and $\hat{\mathbf{h}}^{(0)} = [\hat{\sigma}_{(0)}, 0, \dots, 0]$.

We begin by showing how exploiting FEC can improve channel estimates. Consider the system of Fig. 2, and assume that $K = 2048$ bits are encoded by a rate 1/2 recursive systematic convolutional (RSC) code with parity generator

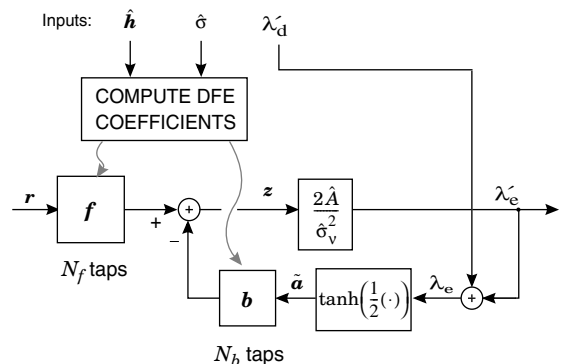

Fig. 4. A soft-output equalizer based on a MMSE-DFE.

polynomial $(1 + D^2)/(1 + D + D^3)$. The resulting 4096 coded bits are interleaved with a random interleaver and transmitted through an ISI channel with $\mathbf{h} = [0.5, 0.7, 0.5]$. We use the DFE-based soft-output equalizer of the previous section, with $N_f = 15$ forward and $N_b = 2$ feedback coefficients. The results in the next two paragraphs were averaged over 200 runs of this experiment.

In Fig. 5 we plot the mean-square estimation error $\text{MSE} = E[\|\hat{\mathbf{h}} - \mathbf{h}\|^2]$ as a function of the per-bit SNR E_b/N_0 after five iterations, for both the proposed estimator that exploits FEC as well as an iterative blind estimator [2] that ignores FEC. Also shown are the same two curves when the DFE is replaced by BCJR. We see that the DFE-based estimator that exploits FEC can attain the same level of accuracy as the one that ignores FEC, but with an SNR that is 6 dB lower. Furthermore, the DFE-based estimator that exploits FEC requires only 2 dB more SNR than the a BCJR-based estimator that exploits FEC, to achieve the same MSE.

It is also interesting to note that the bit-error rate (BER) performance of the proposed blind schemes is comparable to that of a receiver with full channel knowledge. This can be seen in Fig. 6, where we plot the BER versus E_b/N_0 for several iterations of the DFE-based and BCJR-based turbo equalizers with channel knowledge, as well as the channel estimators based on these two algorithms. We see that as the number of iterations increases, the gap between the blind and the non-blind equalizers decreases, until it is almost closed. The blind scheme is seen to converge in about the same number of iterations as the scheme with channel knowledge. Furthermore, we again see that the DFE-based system requires only 2 dB more SNR than the BCJR-based one for a BER of 10^{-2} . This plot also highlights the good use that the

proposed DFE makes of *a priori* information, as evidenced by the 5 dB gap between the first and last iteration of the DFE-based system with channel knowledge.

To analyze the performance of the channel estimator across different channels, we tested its performance over an ensemble of 1000 randomly generated channels. In each case, $K = 400$ message bits were encoded with a rate 1/4 serially concatenated turbo code using two identical rate 1/2 RSC encoders, each with parity generator $(1 + D^2)/(1 + D + D^3)$. The channels were generated randomly according to $\mathbf{h} = \mathbf{u}/\|\mathbf{u}\|$, where $\mathbf{u} \sim \mathcal{N}(\mathbf{0}, \mathbf{I})$ is a circularly symmetric Gaussian random vector of length five, and the noise variance was chosen so that $E_b/N_0 = 2$ dB. The receiver used the BCJR algorithm for both equalization and decoding. The turbo decoder went through only one iteration ($J = 1$) for each iteration of the overall scheme.

In Fig. 7, we plot the estimated probability density function $p_e(e)$ for the estimation error $e = \|\hat{\mathbf{h}} - \mathbf{h}\|$, produced after 60 iterations of the FEC-aware and the FEC-ignorant extended-window channel estimators. We observe that the FEC-aware estimator produced errors larger than -10 dB in only 2.7% of the experiments, while the errors produced by the FEC-ignorant estimator were larger than -10 dB in 82.9% of the experiments. To test the quality of these estimates, we used them to perform a turbo equalization for each trial. After 30 iterations of the turbo equalizer, we could recover the transmitted codeword without errors for 90.7% of the channels using the FEC-aware estimates, while this was possible for only 12.3% of the channels using the FEC-ignorant estimates. The benefit of using FEC information for channel estimation are thus clear.

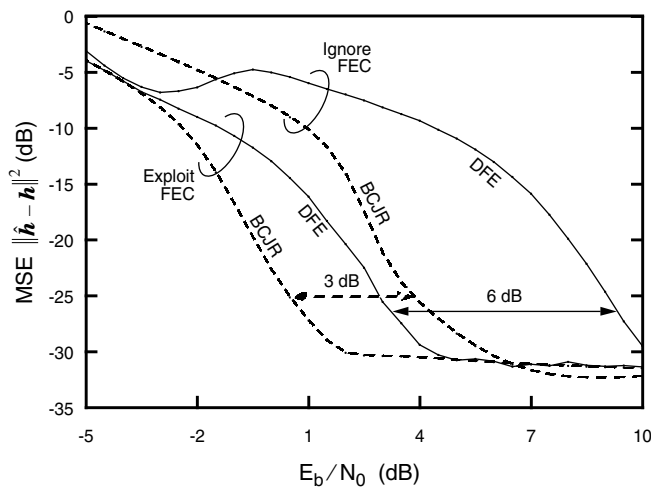

Fig. 5. Mean-square estimation error versus SNR.

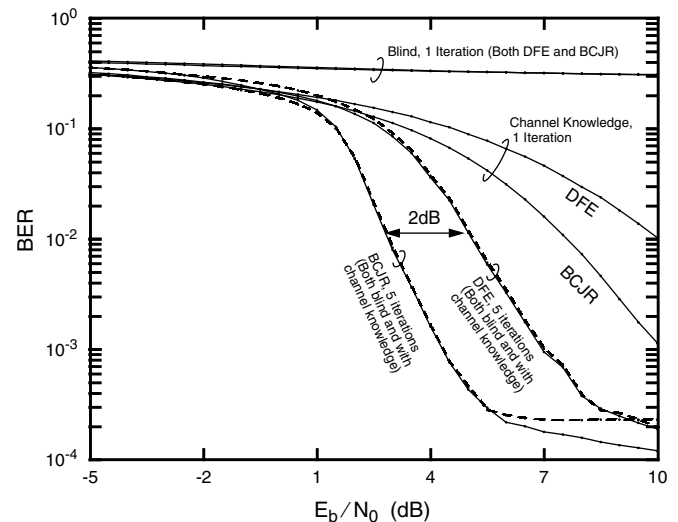

Fig. 6. Bit-error rate versus SNR for both DFE and BCR, both with channel knowledge and using blind estimates.

It is well known that blind channel estimators cannot resolve delays. A blind equalizer that estimates $\hat{a}_k \approx a_{k-1}$ is often just as good as one that estimates $\hat{a}_k \approx a_k$. However, this delay is problematic when the transmitter includes a random interleaver. For example, if we deinterleave a_{k-1} instead of a_k , the result will bear no resemblance whatsoever to c_{k-1} . The frame boundaries must be identified before FEC decoding is meaningful. In the random channel experiment, we assumed perfect frame synchronization. A truly blind frame synchronizer would be difficult to implement in practice. Fortunately, in practice there will exist side information from preambles and pilot symbols that can be used to synchronize the frame in a semiblind fashion.

VII. CONCLUSIONS

We proposed a blind iterative channel estimator that benefits from the presence of forward-error correction coding. The benefits can be significant. In one example, compared to an estimator that ignores FEC, an estimator that exploits FEC can attain the same performance with 6 dB less SNR. In our simulations, the performance of the proposed blind schemes was as good as that of a turbo equalizer with channel knowledge, and it converged equally fast. We also proposed a soft-output equalizer based on a DFE that incorporates *a priori* information. We showed that, even though a blind FEC-aware scheme based on this equalizer performs slightly worse than the scheme based on the BCJR algorithm, the performance of the DFE-based system improves as the iterations progress, providing a gain of 5 dB over a non-iterative system with channel knowledge that employs a conventional DFE followed by a decoder.

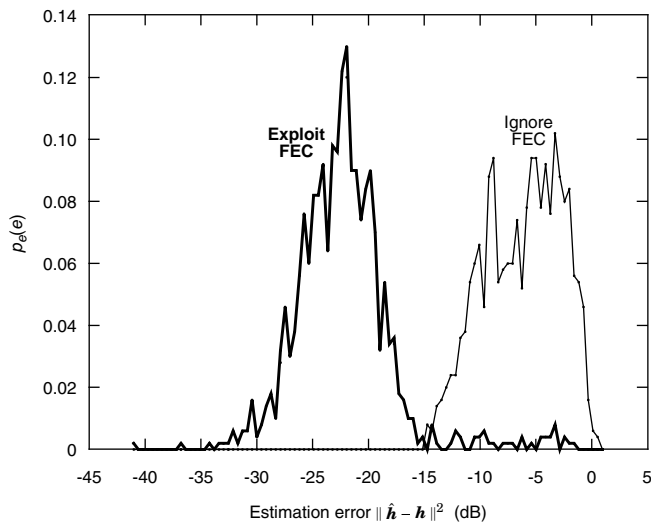

Fig. 7. Estimate of pdf of estimation error $e = \|\hat{\mathbf{h}} - \mathbf{h}\|^2$, estimated from histogram over 1000 random channels.

REFERENCES

- [1] G. K. Kaleh and R. Vallet, "Joint Parameter Estimation and Symbol Detection for Linear or Nonlinear Unknown Channels," *IEEE T. Commun.*, vol. 42, no. 7, pp. 2406-23, July 1994.
- [2] R. R. Lopes and J. R. Barry, "Blind Iterative Channel Identification and Equalization," to appear, *IEEE International Conference on Communications*, Helsinki, June 2001.
- [3] C. Berrou, A. Glavieux and P. Thitimajshima, "Near Shannon Limit Error-Correcting Coding and Decoding," *IEEE International Conference on Commun.*, pp. 1064-1070, May 1993.
- [4] D. J. MacKay, "Good Error Correcting Codes Based on Very Sparse Matrices," *IEEE T. Info. Theory*, p. 399-431, May 1999.
- [5] S. Benedetto, D. Divsalar, G. Montorsi and F. Pollara, "Serial Concatenation of Interleaved Codes: Performance Analysis, Design and Iterative Decoding," *IEEE Trans. Information Theory*, vol. 44, no. 3, pp. 909-926, May 1998.
- [6] J. Mannerkoski and V. Koivunen, "Autocorrelation Properties of Channel Encoded Sequences - Applicability to Blind Equalization," *IEEE Trans. Signal Proc.* vol. 48, no. 12, Dec 2000.
- [7] J. Garcia-Frias and J. D. Villasenor, "Blind Turbo Decoding and Equalization," *IEEE Vehicular Technology Conference*, pp. 1881-1885, v. 3, May 1999.
- [8] J. Garcia-Frias and J. D. Villasenor, "Combined Blind Equalization and Turbo Decoding," *IEEE Communications Theory Mini-Conference*, pp. 52-57, June 1999.
- [9] P. Ha and B. Honary, "Improved Blind Detector," *IEEE Vehicular Technology Conference*, pp. 1196-1199, v. 2, May 2000.
- [10] A. Glavieux, C. Laot and J. Labat, "Turbo Equalization Over a Frequency Selective Channel," *International Symposium on Turbo Codes and Related Topics*, Brest, France, pp. 96-102, Sep 1997.
- [11] D. Raphaeli and Y. Zarai, Y, "Combined turbo equalization and turbo decoding," *IEEE Communications Letters*, vol. 2, no.4, pp.107-109, April 1998.
- [12] C. Douillard, M. Jezequel, C. Berrou, A. Picart, P. Didier, and A. Glavieux, "Iterative correction of intersymbol interference: turbo-equalization," *European Transactions on Telecommunications*, vol. 6, no.5, pp.507-511, Sept.-Oct. 1995.
- [13] L. R. Bahl, J. Cocke, F. Jelinek, and J. Raviv, "Optimal Decoding of Linear Codes for Minimizing Symbol Error Rate," *IEEE Trans. on Info. Theory*, pp. 284-287, March 1974.
- [14] E. A. Lee and D. G. Messerschmitt, *Digital Communication*, Second Edition, Kluwer Academic Publishers, 1994.
- [15] Poor, H. V., *An Introduction to Signal Detection and Estimation*, Second Edition, Springer-Verlag, 1994.
- [16] W. Zi-Ning Wu and J. M. Cioffi, "Turbo Decision Aided Equalization for Magnetic Recording Channels," *IEEE GLOBECOM'99*, vol. 1b, pp.733-8, Brazil, 1999.